



Frazivel
metalomecânica

**WE MAKE YOUR WORK
EASIER**

2016



WHO WE ARE AND WHAT WE DO



Fravizel
metalomecânica



30 years
making history



WHO WE ARE

- Engineering and Metalworking company
- Beginning of activity: 1998
- 50 Employees

30 YEARS MAKING HISTORY EVENT





Fravizel
metalomecânica



30 years
making history



WHAT MAKE US DIFFERENT

- SME Innovation Network AT COTEC

-Strong R&D:

- Patented products;

- In 2015, we have sent Forks to CAT in USA to be tested in the the new CAT 980M





Fravizel
metalomecânica

ISO 9001
BUREAU VERITAS
Certification



ISO 14001
BUREAU VERITAS
Certification



30 years
making history

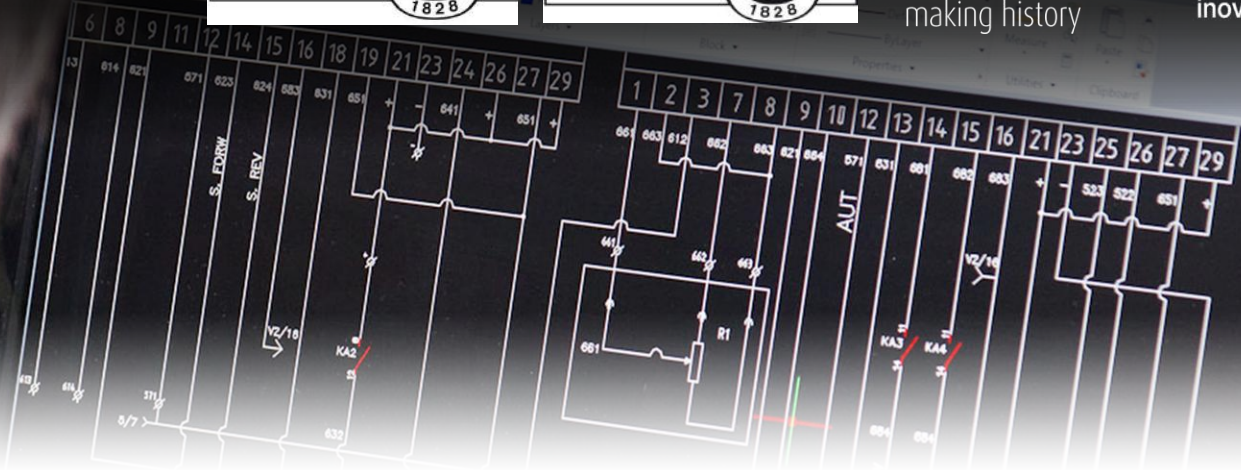

WHAT MAKE US DIFFERENT

ISO 9001
BUREAU VERITAS
Certification



ISO 14001
BUREAU VERITAS
Certification



- In labor at the Natural Park of *Serra de Aire and Candeeiros*, Fravizel has certified its management system in quality and environment by ISO 9001 and ISO 14001 standards.
- Our mission is to provide security to the users of our machines.

INDUSTRY

MINES

PORT

FORESTRY

CONSTRUCTION AND
PUBLIC WORKS

NATURAL STONE





ATTACHMENTS FOR EARTHMOVING MACHINERY



Fravizel
metalomecânica

ISO 9001

BUREAU VERITAS
Certification



ISO 14001

BUREAU VERITAS
Certification



30 years
making history





Fravizel
metalomecânica

ISO 9001

BUREAU VERITAS
Certification



ISO 14001

BUREAU VERITAS
Certification



30 years
making history

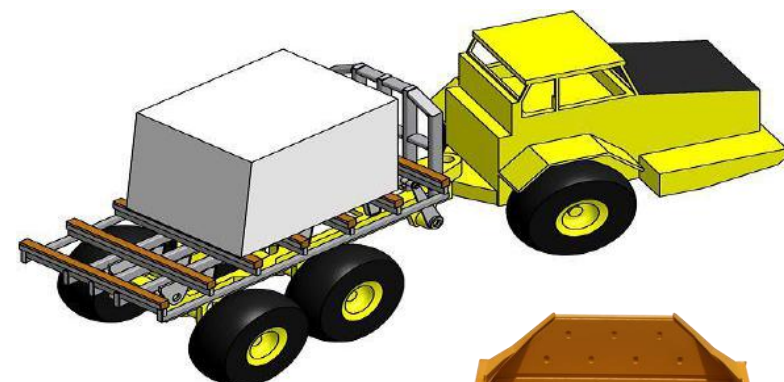



MACHINERY

NATURAL STONE

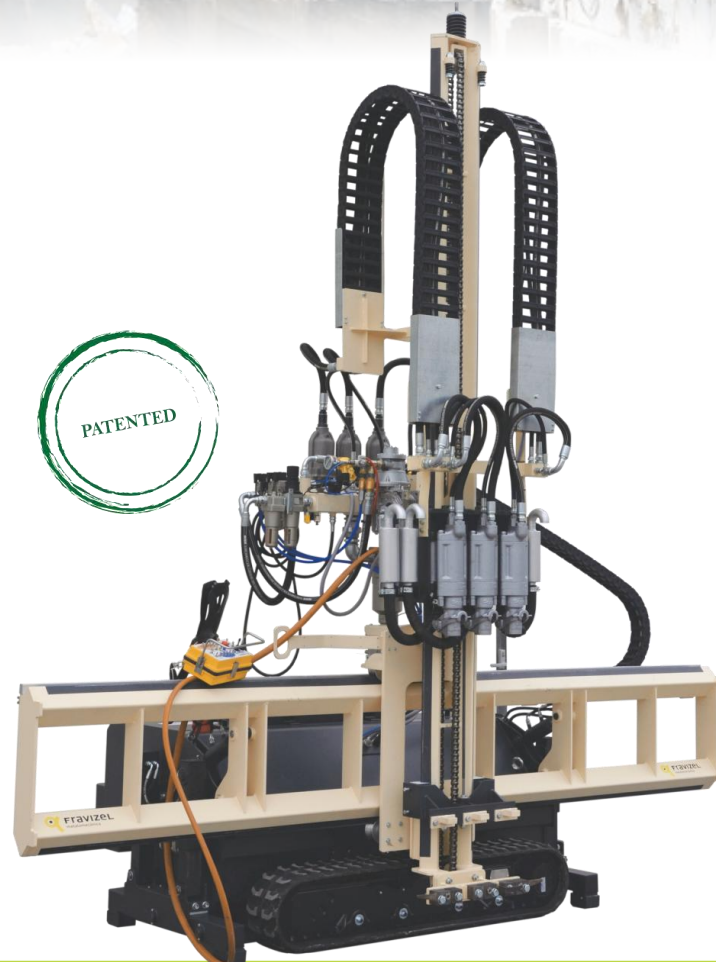



NATURAL STONE

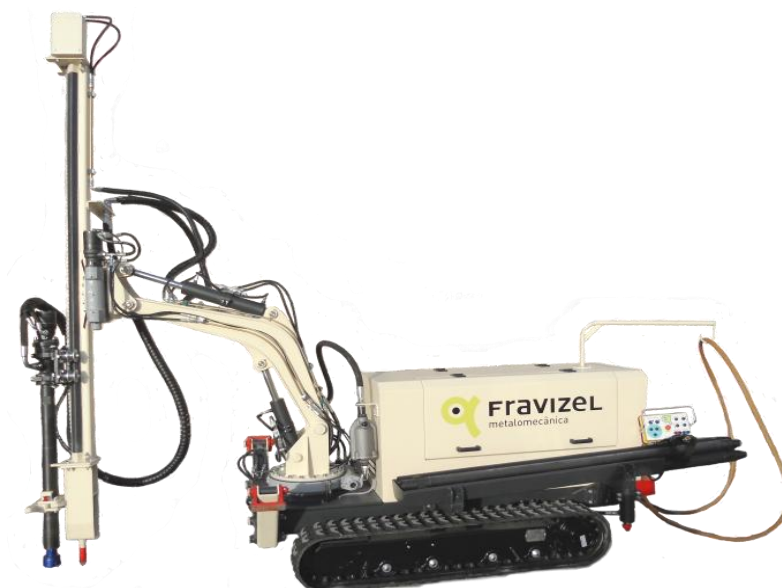



NATURAL STONE

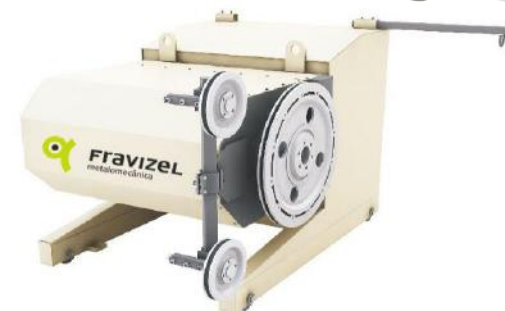
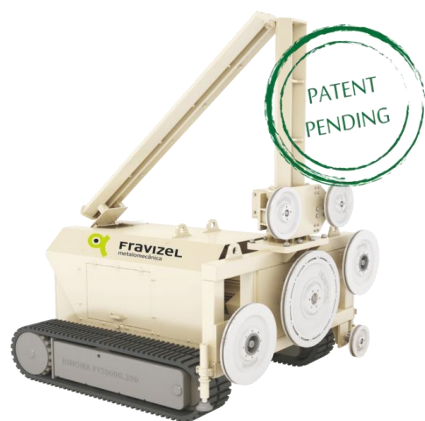



NATURAL STONE



NATURAL STONE

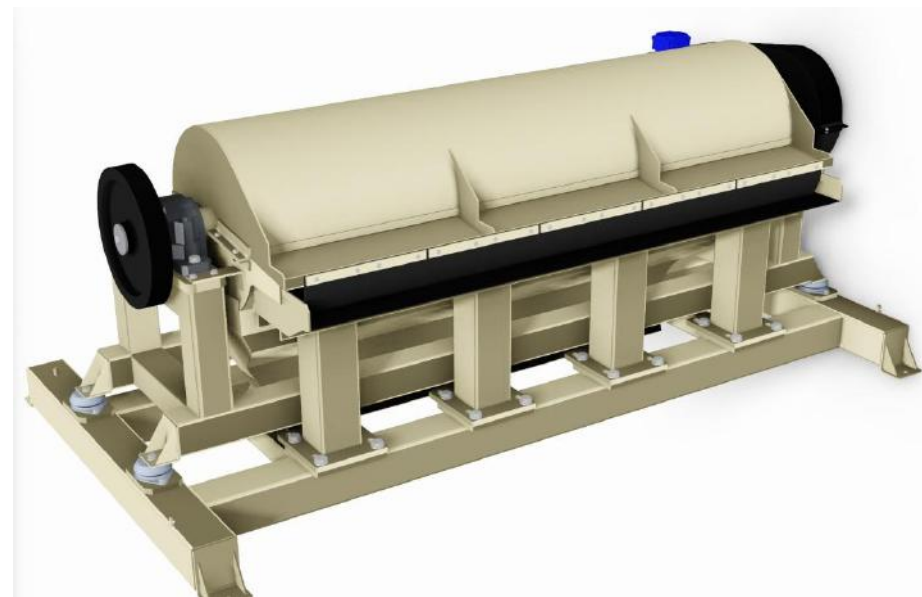



Fravizel
metalomecânica

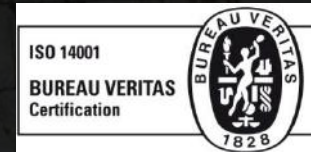

30 years
making history



NATURAL STONE

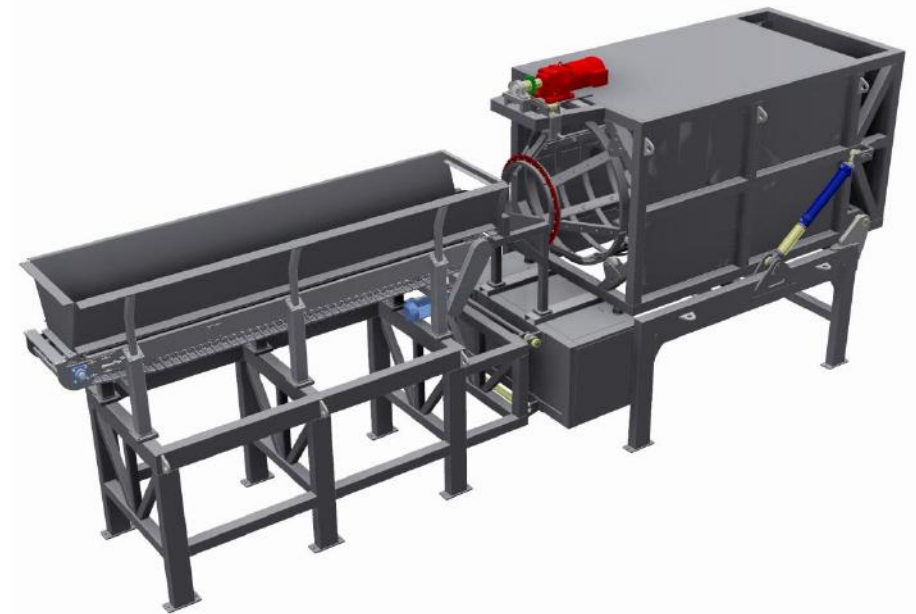
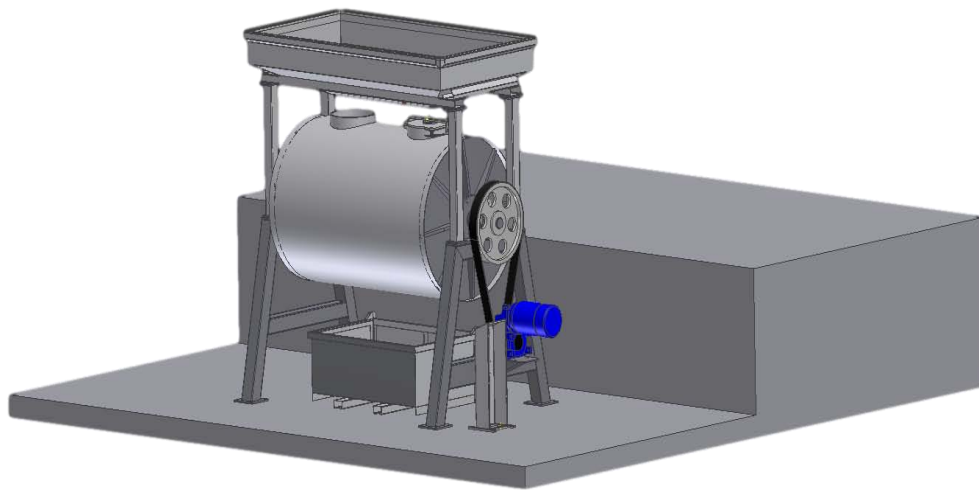



Fravizel
metalomecânica



30 years
making history



NATURAL STONE

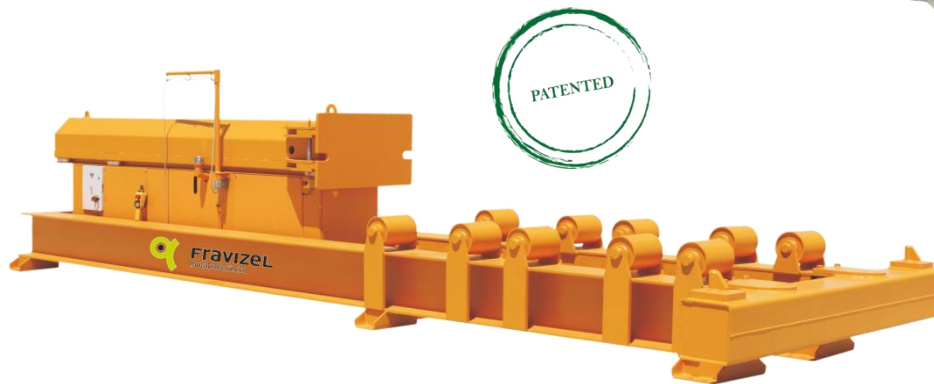

INDUSTRY



INDUSTRY





Fravizel
metalomecânica



30 years
making history



INDUSTRY





SERVICES



Fravizel
metalomecânica



30 years
making history



SERVICES

- Plate cutting and bending
- Steel bar cutting
- Welding and assembly
- Machining
- Execution and application of hydraulic circuits and automatic lubrication
- Finishingins
- Repairs

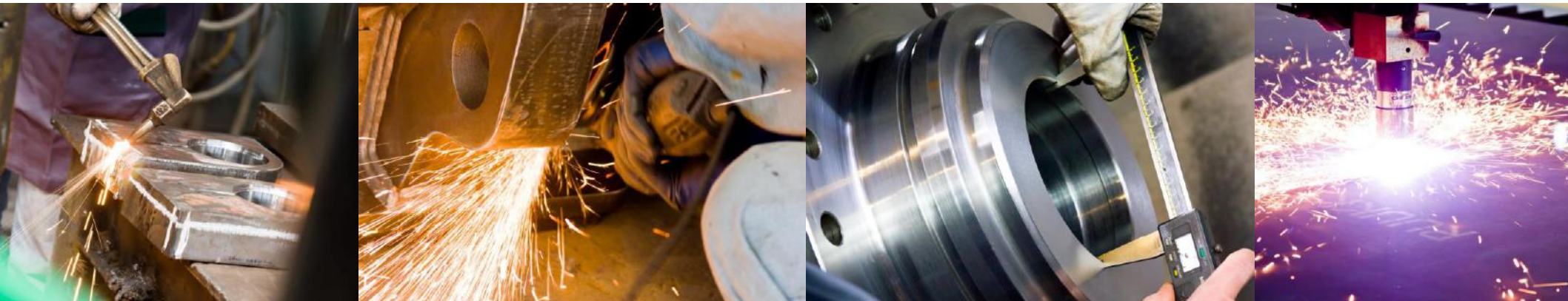



Fravizel
metalomecânica



30 years
making history



Estrada 5 de outubro, Apartado 47
Pé da Pedreira, 2025-999 Alcanede, Portugal
GPS 39°27'11.40N 8°50'32.00W

Tel: +351 243 40 92 20 | Fax: +351 243 40 92 21

Email: geral@fravizel.com
Sales: sales@fravizel.com





WHERE TO FIND US

**VITÓRIA
STONE FAIR**
MARMOMACC
LATIN AMERICA

16-19 FEVEREIRO 2016
ESPÍRITO SANTO - BRASIL



FORTALEZA
BRAZIL STONE FAIR

Visit us! Open-air
ground FN.821/3



bauma 2016
April 11-17, Munich

O DESTINO
CERTO PARA
GRANDES
NEGÓCIOS

**CACHOEIRO
STONE FAIR**

**FEIRA NACIONAL
DA FLORESTA**
CONVITE



22 a 25 abril
EXPOCENTRO POMBAL'16

42ª FEIRA INTERNACIONAL
EDIÇÃO DO MÁRMORE E GRANITO
INTERNATIONAL MARBLE AND GRANITE FAIR

23 - 26
AGOSTO 2016

CACHOEIRO DE ITAPEMIRIM
ESPÍRITO SANTO - BRASIL

MARMOMACC
STONE + DESIGN + TECHNOLOGY INTERNATIONAL TRADE FAIR

ITALY - Verona,
28th SEPTEMBER - 1st OCTOBER 2016



coremaq
reparação de máquinas



2016



WHO WE ARE AND WHAT WE DO



coremaq
reparação de máquinas

30
years
making history



WHO WE ARE

- Heavy Duty Mechanic Workshop
- Beginning of activity: 1984
- 15 Employees





coremaq
reparação de máquinas

30
years
making history



Business Portfolio

- Sale of Industrial Machinery: Excavator, Wheel Loader, Dumpers, Air Compressors, Power Generators.
- Earthmoving machinery attachments
- Quarry Wear Parts;
- Consultancy;
- Workshop
- Hydraulic circuits and automatic lubrications





Products



AIR COMPRESSORS AND TANKS



GENERATORS



BATTERIES



FUEL TANKS



LUBRICANTS



HYDRAULIC BREAKERS



Products



GRABS



DEMOLITION TOOLS
SHEARS, PULVERIZERS, COMPACTORS



TYRE PROTECTION CHAINS



GROUND ENGAGING TOOLS
SPARE PARTS FOR EARTHMOVING



AIR PUSHING BAG & WIRE DIAMOND



HAMMERS, CHISELS



INTEGRAL AND TAPERED DRILL RODS,
SPLITTERS, TAPERED BUTTON BITS



COUPLINGS,
AIR HOSE



HYDRAULIC PIPES AND ACCESSORIES



coremaq
reparação de máquinas

30
years
making history

Services

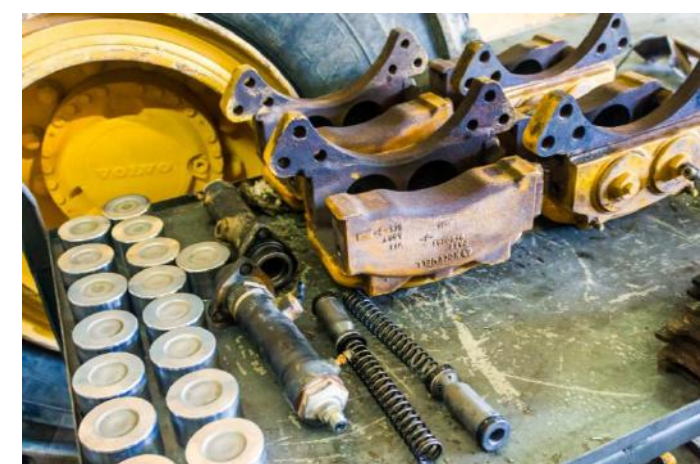



coremaq
reparação de máquinas

30
years
making history

Services





THANK YOU