

DESIGNED BY: [Name] DRAWN BY: [Name] CHECKED BY: [Name] APPROVED BY: [Name]		PROJECT: [Name] SHEET NO: 2 OF 5 PART NUMBER: Q15850534970	TITLE: HYDROVAC RECYCLING SYSTEM DRAWN BY: MTG CHECKED BY: [Name]	SHEET NO: D PART NUMBER: Q15850534970	SHEET NO: 5
--	--	--	---	--	-------------

PRELIMINARY DRAWING  
 ALL DIMENSIONS SHOWN ARE AS SHOWN UNLESS OTHERWISE SPECIFIED  
 ALL DIMENSIONS ARE IN METERS UNLESS OTHERWISE SPECIFIED  
 ALL DIMENSIONS ARE TO FACE UNLESS OTHERWISE SPECIFIED  
 ALL DIMENSIONS ARE TO CENTERLINE UNLESS OTHERWISE SPECIFIED  
 ALL DIMENSIONS ARE TO CENTERLINE UNLESS OTHERWISE SPECIFIED  
 ALL DIMENSIONS ARE TO CENTERLINE UNLESS OTHERWISE SPECIFIED

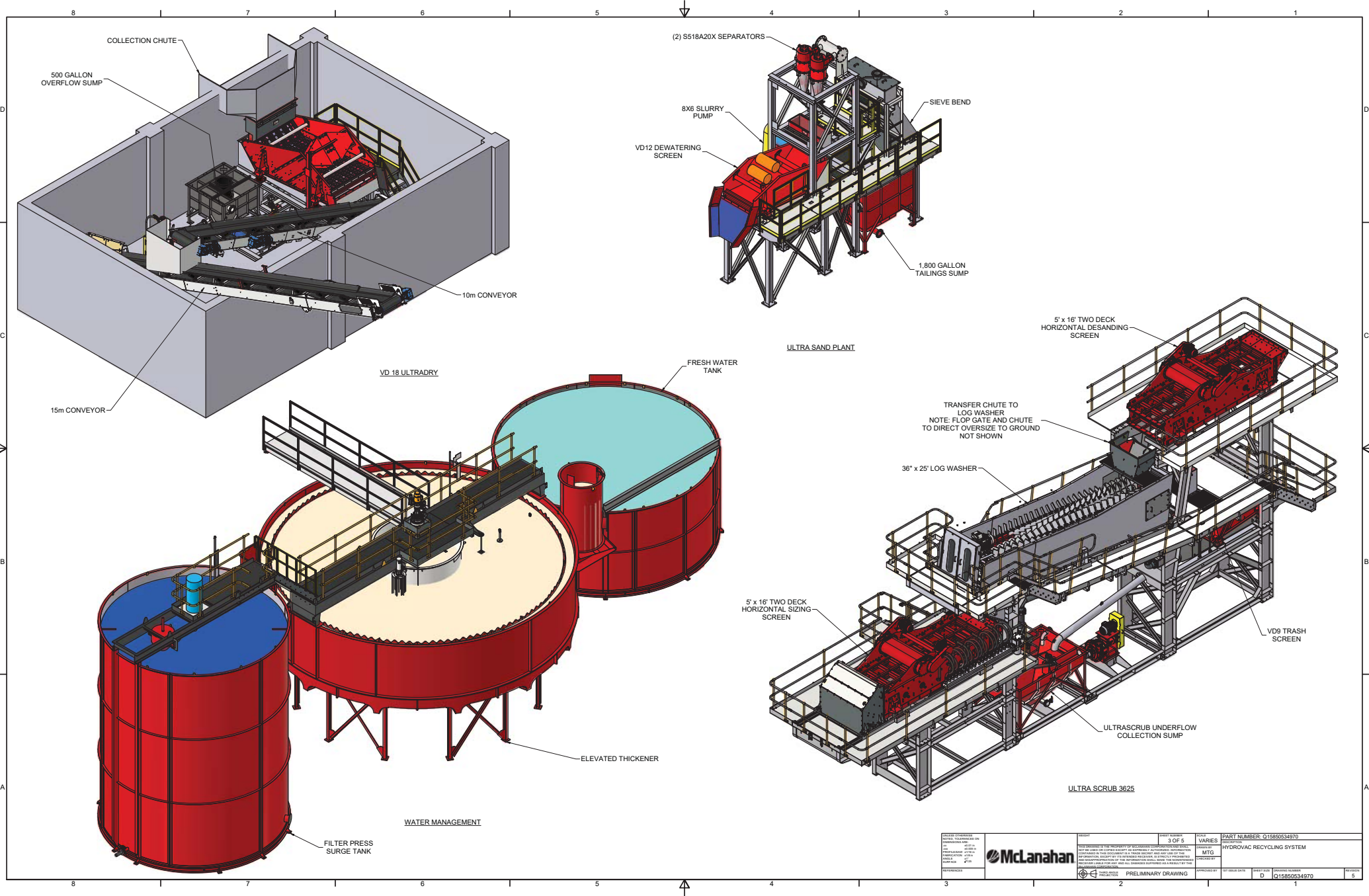

DESIGN: [unreadable] DRAWN: [unreadable] CHECKED: [unreadable] APPROVED: [unreadable]	PROJECT: [unreadable]	SHEET NUMBER: <b>3 OF 5</b>	SCALE: <b>VARIES</b>	PART NUMBER: Q15850534970
			PROJECT: [unreadable]	PROJECT: [unreadable]
PRELIMINARY DRAWING			SHEET DATE: <b>D</b>	DESIGN NUMBER: <b>Q15850534970</b>
				SHEET NO: <b>5</b>

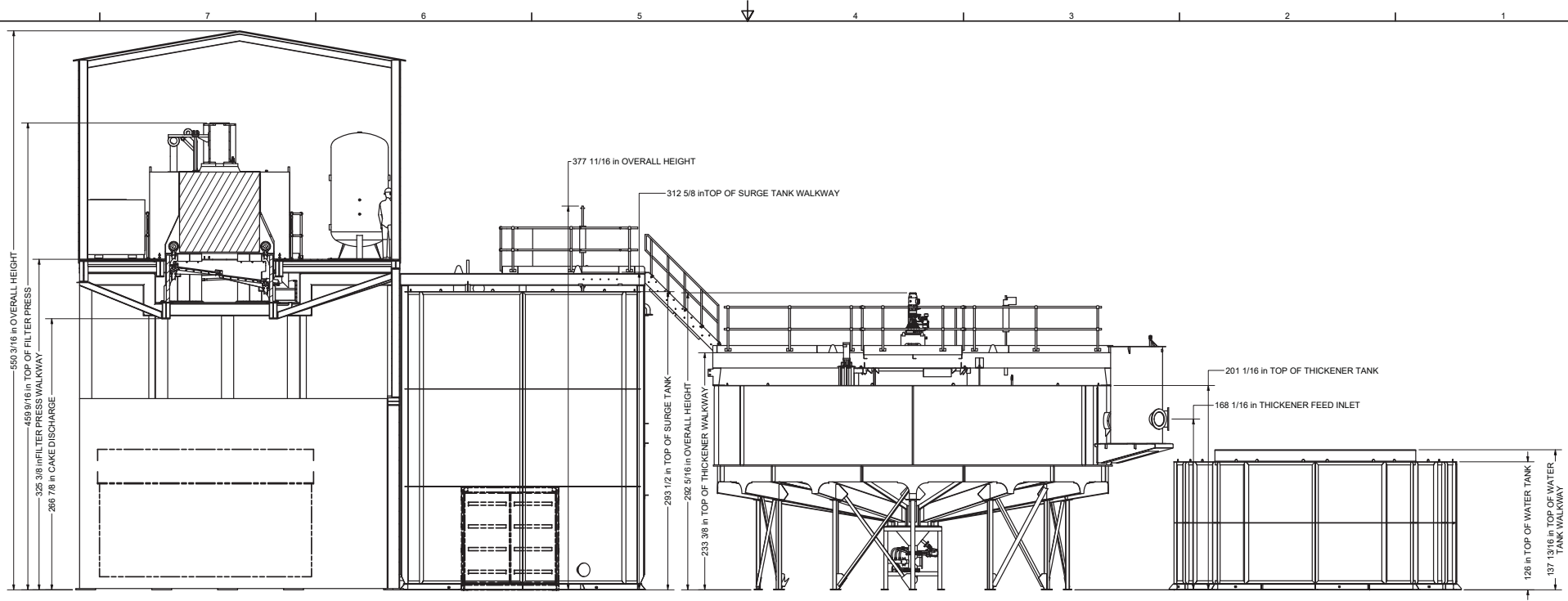

SECTION A-A  
TAILINGS ELEVATIONS  
SCALE 1:50

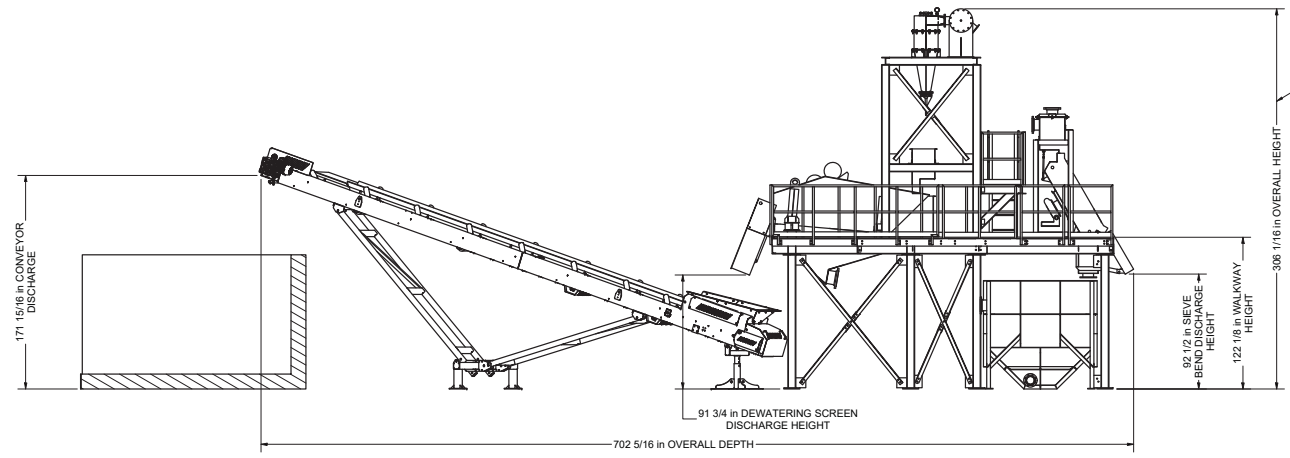

SECTION B-B  
SAND PLANT ELEVATIONS  
SCALE 1:50

DESIGN APPROVED BY: DATE: 02/11/2014 PROJECT NO: 13100000000000000000 DRAWING NO: 13100000000000000000 SHEET NO: 4 OF 5	DESIGNED BY: DATE: 02/11/2014 PROJECT NO: 13100000000000000000 DRAWING NO: 13100000000000000000 SHEET NO: 4 OF 5	CHECKED BY: DATE: 02/11/2014 PROJECT NO: 13100000000000000000 DRAWING NO: 13100000000000000000 SHEET NO: 4 OF 5	DRAWN BY: DATE: 02/11/2014 PROJECT NO: 13100000000000000000 DRAWING NO: 13100000000000000000 SHEET NO: 4 OF 5	PART NUMBER: 015850534970 HYDROVAC RECYCLING SYSTEM
				PRELIMINARY DRAWING
SHEET NO: D DESIGN NUMBER: 015850534970				SHEET NO: 5

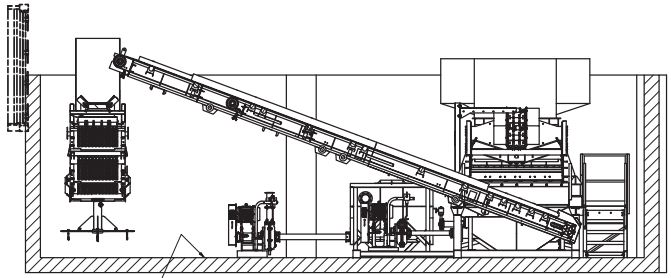

SECTION D-D  
ULTRA DRY ELEVATIONS  
SCALE 1" = 50'

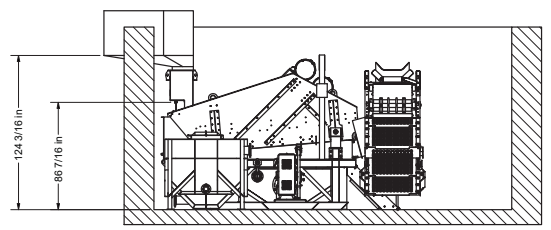

SECTION F-F  
SCALE 1" = 50'

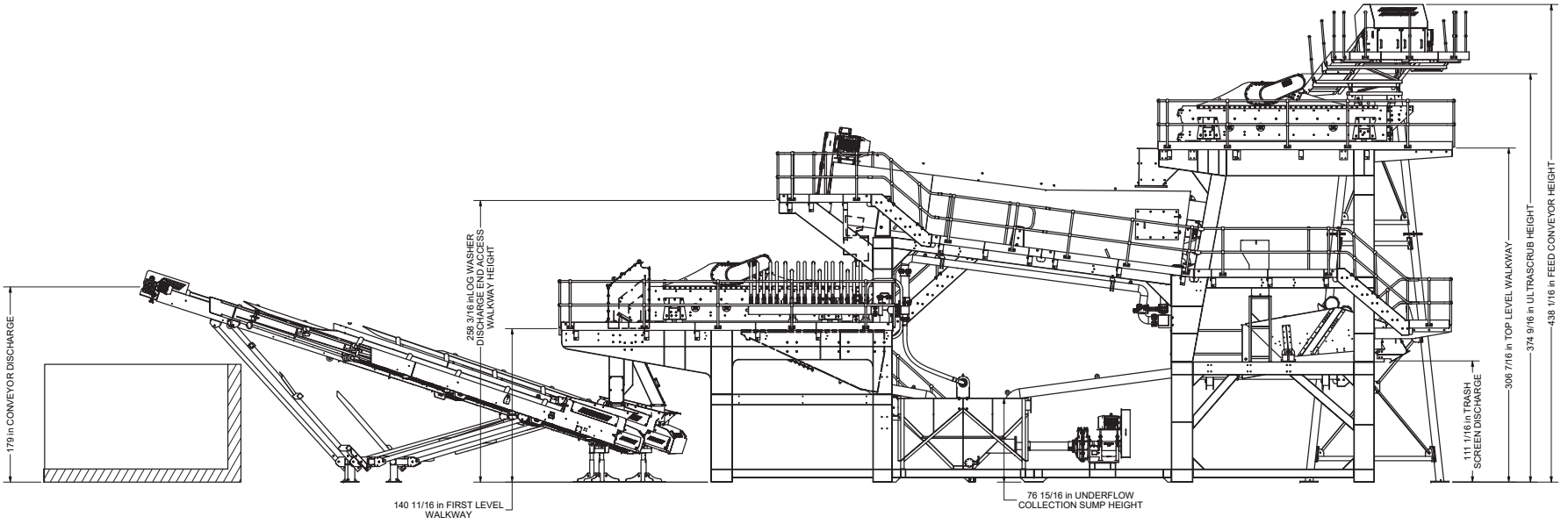

SECTION C-C  
ULTRASCUB ELEVATIONS  
SCALE 1" = 50'

DESIGN: MCGRAW-HILL DATE: 02/11/10 PROJECT: 015850534970 DRAWING: 015850534970-01 SHEET: 5 OF 5		PREPARED BY: MCGRAW-HILL CHECKED BY: MCGRAW-HILL DATE: 02/11/10 PROJECT: 015850534970 DRAWING: 015850534970-01 SHEET: 5 OF 5	PART NUMBER: 015850534970 HYDROVAC RECYCLING SYSTEM PRELIMINARY DRAWING
---	--	---	---