

WATER TREATMENT & SILT MANAGEMENT



THE EXCELLENCE IN **WASHING**, BY NATURE

WASHING | PRESENTATION

Matec has developed exhaustive experience in the water treatment sector with **over 2500 installations** worldwide

Recovering water in any kind of industrial application, including **aggregates and sand washing**.

Through our **washing equipment**, we complete the cycle of the use of water for industrial purposes.



When there are **specific requirements** in terms of product size and quality

For a **specific market or projects**, whenever there is the need of giving new value to waste material

To bring the raw material within specification, by **removing impurities** such as Silt, Clay & General Contaminants

To facilitate the commercial use of otherwise low-grade materials (e.g. quarry overburden) / by-products (e.g. crusher dust) / waste (e.g. demolition materials, old tailings ponds).



Granulometry of Final Aggregate Products:

Clay = 0 - 4 μm

Silt = 4 – 75 μm

Fine Sand = 75 μm – 2 mm

Coarse Sand = 2 mm – 6 mm

Fine Gravel = 6mm – 9mm

Medium Gravel = 9 – 16 mm

Coarse Gravel = 16 – 32 mm





AGGRETEC Washed sand and aggregates / minerals



SCREENTEC Washed and sized (all materials)



SANDTEC Washed & dewatered sand / minerals



ATTRITEC Decontaminated sand / minerals



SCRUBTEC Washed aggregates / minerals



BUCTEC Washed and dewatered sand / minerals

THICKENER Waste water treatment plant
FILTERPRESS Silt treatment plant

Aggretec is Matec's **rapid installation** modular washing platform for a wide range of sectors including aggregates, recycling, remediation and mining. Since the system is **semi-mobile**, it is highly portable so also ideal for working in construction and demolition Sites.

Aggretec integrates the following items into a single platform machine:

- Feed hopper and conveyor
- Washing screen (multi-deck)
- Fines recovery / sand washing unit
- Stockpile conveyors
- Electrical controls and pre-wiring
- All structures and walkways
- Comprehensive options / potential to customise for specific applications



- 1 Raw material fed from feeding hopper and goes through the main conveyor
- 2 Screen, washing & selection of materials
- 3 Slurry (sand & water)
- 4 Cyclone overflow to water treatment (water & silt)

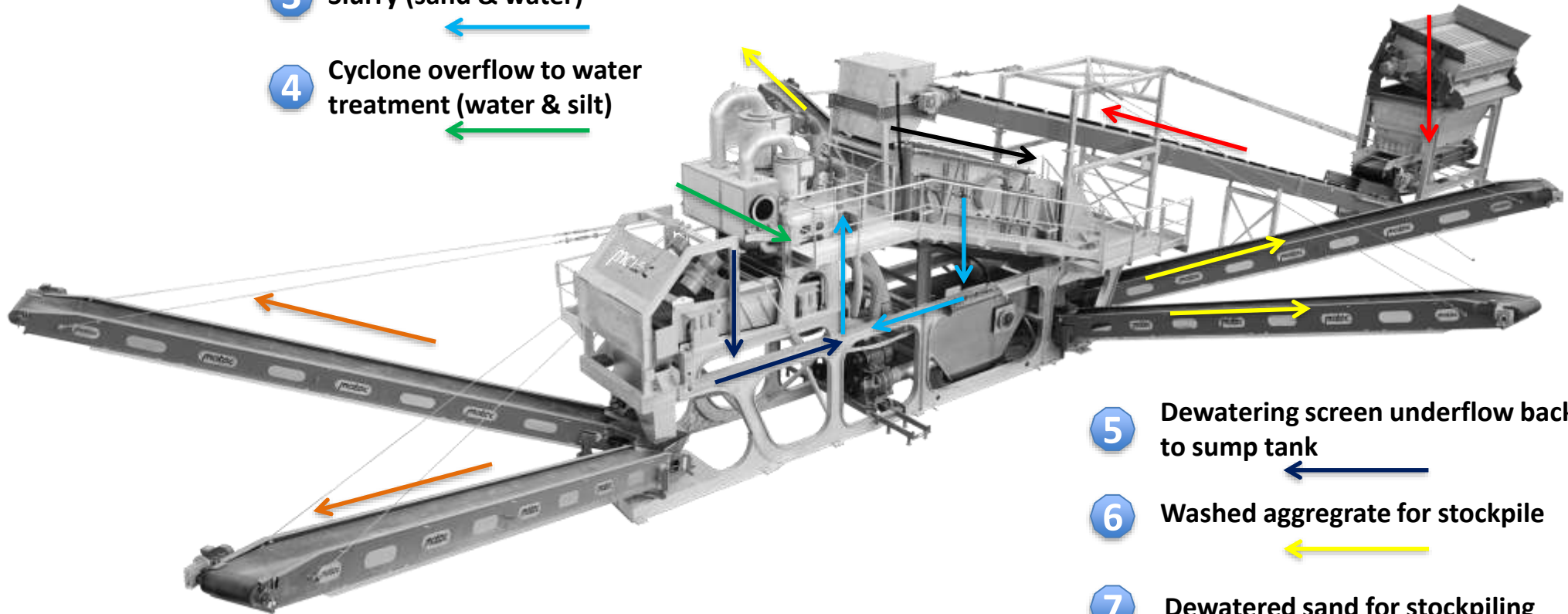

- 5 Dewatering screen underflow back to sump tank
- 6 Washed aggregate for stockpile
- 7 Dewatered sand for stockpiling



ADVANTAGES

- ✓ UP TO 4 GRADES OF AGGREGATE AND 1 OR 2 GRADES OF SAND
- ✓ MODULAR DESIGN, PRE-TESTED
- ✓ COMPLETELY PRE-WIRED WITH PLC CONTROL PANEL
- ✓ RUBBER LINED PUMPS, CYCLONES AND CHUTES/PIPES FOR EXTENDED PLANT LIFE
- ✓ TRANSPORTABLE

COMPOSED OF:

1. FEEDING HOPPER WITH GRID
2. BELT FEEDER
3. FEEDING CONVEYOR BELT
4. VIBRATING SCREEN
5. POLYURETHANE PANELS



COMPOSED OF:

- 5. HYDROCYCLONE (S) GROUP
- 6. SLURRY PUMPS
- 7. DEWATERING SCREEN
- 8. CONVEYOR BELTS FOR FINAL PRODUCT
- 9. SUPPORTING STRUCTURE ON SKID



PARTS

WASHING | PRESENTATION

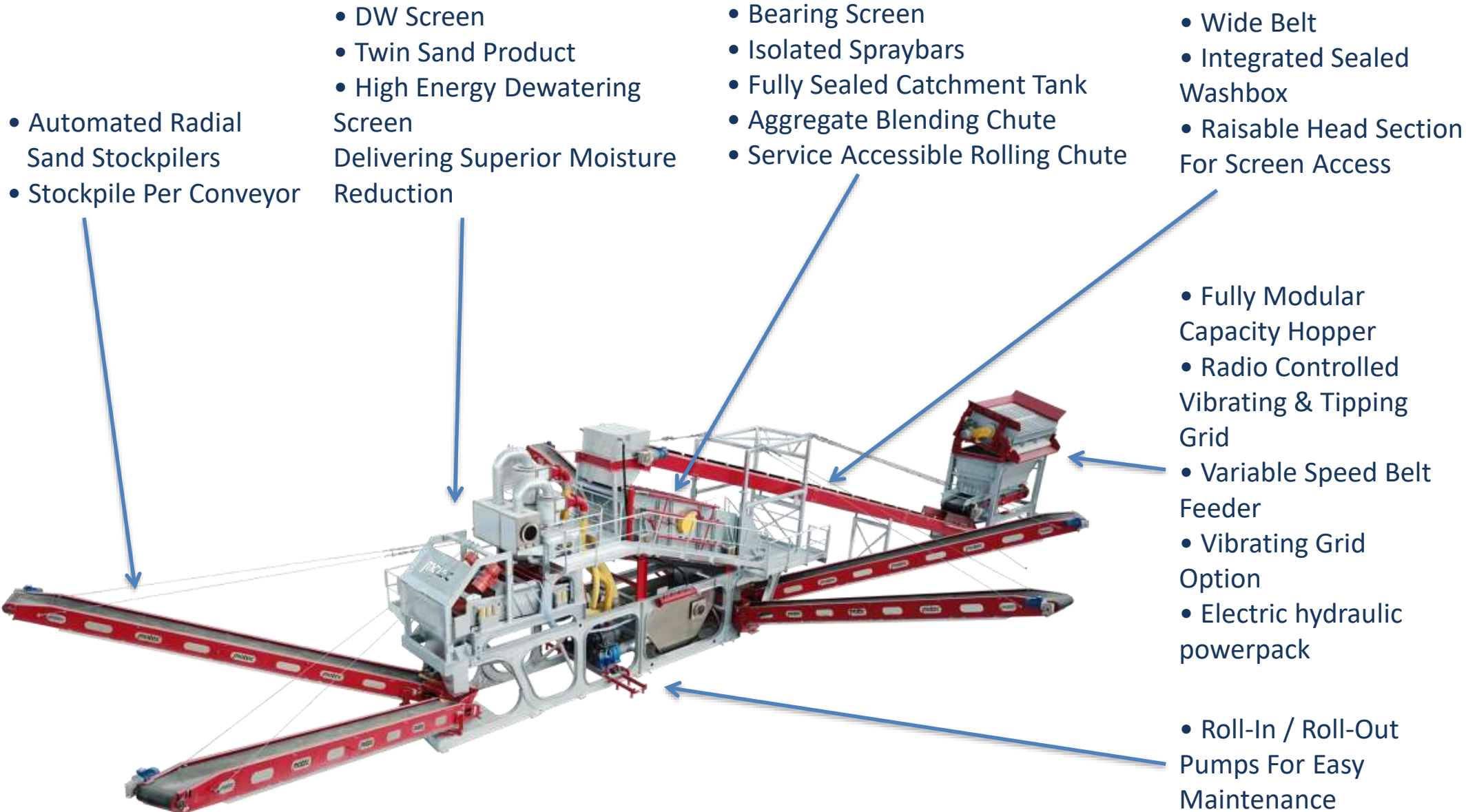

- Automated Radial Sand Stockpilers
- Stockpile Per Conveyor

- DW Screen
- Twin Sand Product
- High Energy Dewatering Screen
- Delivering Superior Moisture Reduction

- Bearing Screen
- Isolated Spraybars
- Fully Sealed Catchment Tank
- Aggregate Blending Chute
- Service Accessible Rolling Chute

- Wide Belt
- Integrated Sealed Washbox
- Raisable Head Section For Screen Access

- Fully Modular Capacity Hopper
- Radio Controlled Vibrating & Tipping Grid
- Variable Speed Belt Feeder
- Vibrating Grid Option
- Electric hydraulic powerpack

- Roll-In / Roll-Out Pumps For Easy Maintenance

OPTIONALS:

- ✓ ELECTRICAL INSTALLATION
- ✓ OVERBAND MAGNET ON FEED CONVEYOR
- ✓ SCALPER SCREEN ON THE HOPPER
- ✓ TANK AND HYDROCYCLONES IN AISI STAINLESS STEEL
- ✓ POLYURETAN PANELS
- ✓ SIEMENS TABLET HMI – MODEL SIMATIC ITP1000



Component	AGGRETEC AGT 50		AGGRETEC AGT 100		AGGRETEC AGT 150		AGGRETEC AGT 200		AGGRETEC AGT 250	
	Model	Power	Model	Power	Model	Power	Model	Power	Model	Power
Hopper+grid+hydraulic unit	8 m3 capacity	4	8 m3	4	10 m3	4	10 m3	4	10 m3	4
Belt feeder	W650 L3900	4 + VFD	W800 L3900	5.5 + VFD	W800 L3900	5.5 + VFD	W1000 L3900	7.5 + VFD	W1000 L3900	9 + VFD
Main conveyor belt	W650 L15000	4 x 2	W800 L15000	4 x 2	W800 L18000	5.5 x 2	W1000 L18000	7.5 x 2	W1000 L21000	9 x 2
Inclined vibrating screen	W1200 L4000 3D	11	W1500 L4000 3D	11	W1500 L5000 3D	15	W1800 L5000 3D	18.5	W1800 L6000 3D	22
Dewatering screen	W1200 L3000 2C	4 x 2	W1500 L3000 2C	5.5 x 2	W1800 L3000 2C	6 x 2	W1500 L4000 2C	7 x 2	W1800 L4000 2C	7.5 x 2
Slurry centrifugal pump for coarse sand	model 4/3 CAH	22 + VFD	6/4 DAH	30 + VFD	6/4 DAH	37 + VFD	8/6 EAH	45 + VFD	8/6 EAH	55 + VFD
Slurry centrifugal pump for fine sand	model 4/3 CAH	22 + VFD	6/4 DAH	30 + VFD	6/4 DAH	37 + VFD	8/6 EAH	45 + VFD	8/6 EAH	55 + VFD
Hydrocyclone for coarse sand	D500		D600		D800		D800		D800	
Hydrocyclone for fine sand	D400		D500		D600		D600		D600	
Storage conveyor belts (n°5)	W500 L10000	3 x 5	W500 L10000	3 x 5	W650 L10000	4 x 5	W650 L10000	4 x 5	W650 L10000	4 x 5

* The data provided is indicative, the dimensions must be confirmed based on the granulometric curve of the material to be treated.

Screeotec is the machine that **washes** and **selects** materials as gravel, coal, crushed stone, slag, recycled materials, concrete, iron ore and silica glass, with high efficiency.

The screen parts are easy to mount and assemble and make the **Screeotec** a suitable match for the other washing machines.

You can install **2 or 3 decks** and choose among several media options.



They mainly consist of a **deck-holding body** suspended on helical springs, a central **protection guard for the shaft**, a **mesh tensioning system** with a metal rod, a **steel alloy shaft**, **grease lubricated bearings** protected by a set of labyrinth flanges, **adjustable eccentric weights** for output variation, a **rear feeding chute** and **hoppers** bolted onto the front part of the machine for material discharge

Screen Mesh Example

Top = 12mm / ½"
Middle = 9mm / ⅜"
Bottom = 6mm / ¼"

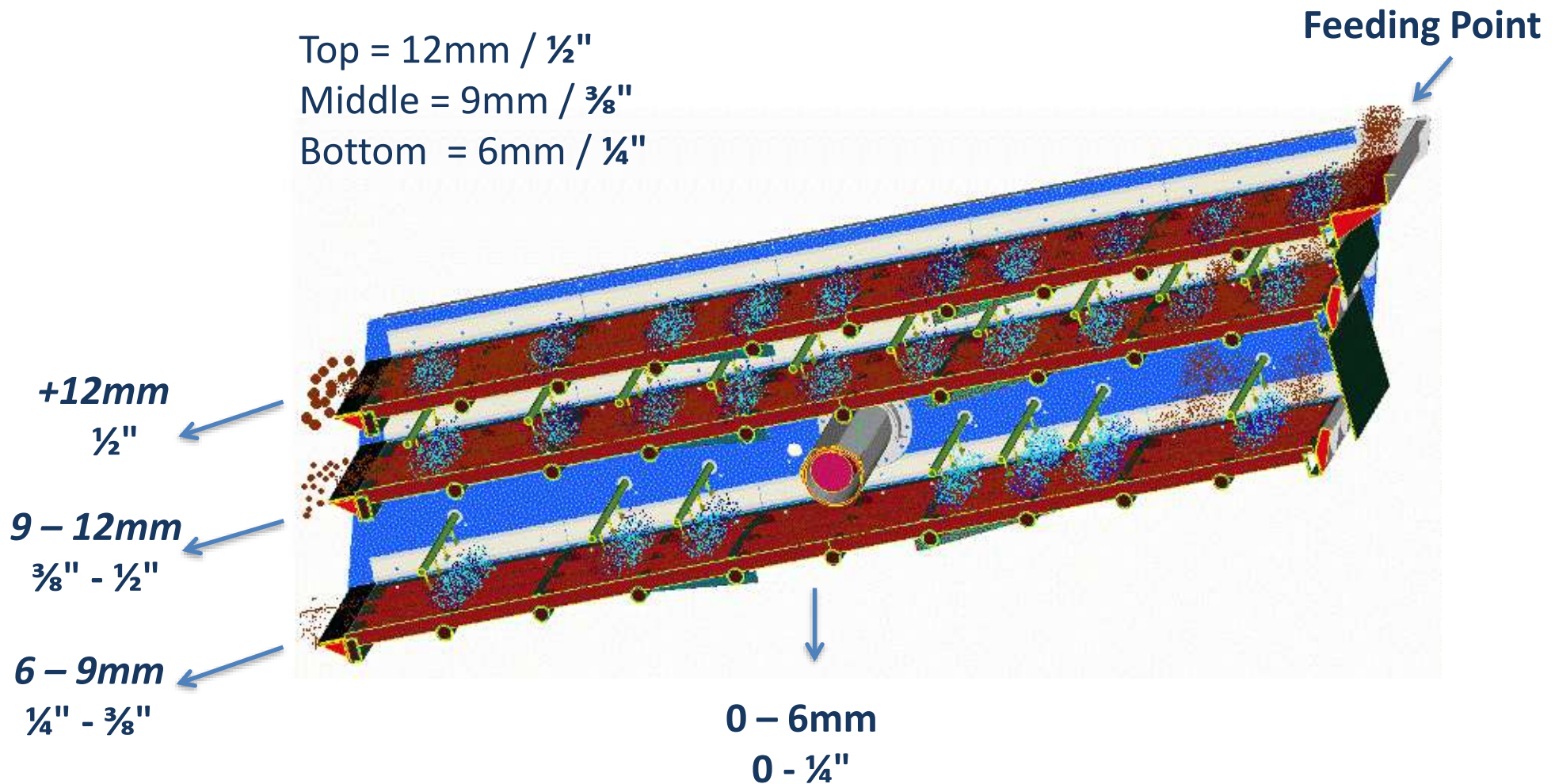

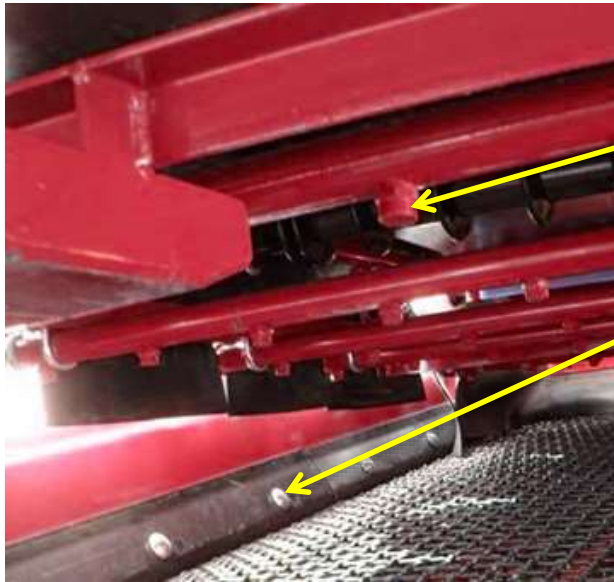

Brass Nozzle

Side Tensioned

Plastic Nozzle

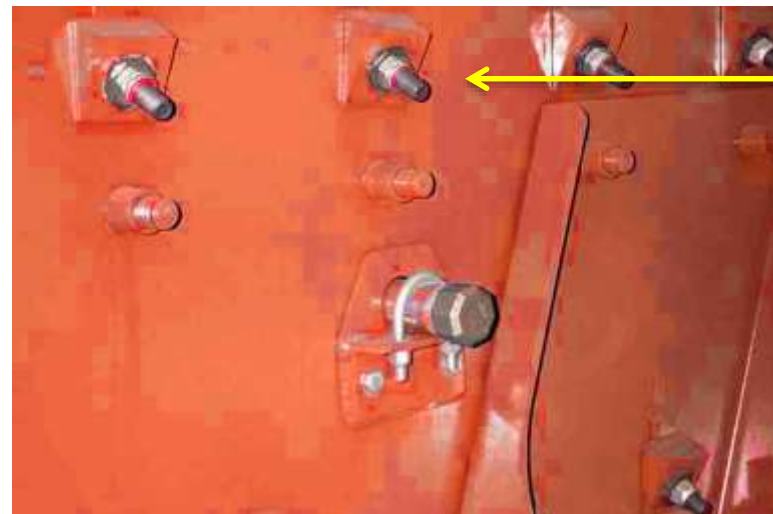

Bolt Side Tensioned



ADVANTAGES

- ✓ UP TO 4 TYPES OF WASHED AGGREGATES AND 1 OR 2 GRADES OF SAND
- ✓ LOW MAINTENANCE FOR HIGH EFFICIENCY
- ✓ EASY REPLACEMENT
- ✓ CUSTOM CHOICE FOR MESHES AND DECKS
- ✓ EASY ASSEMBLING AND MOUNTING

COMPOSED OF:

1. VIBRATING SCREEN
2. 2, 3 OR 4 DECKS
3. WASHING SYSTEM
4. SUPPORTING FRAME ON SKID
5. HOPPERS AND CHUTES
6. SERVICE WALKWAY AND LADDER

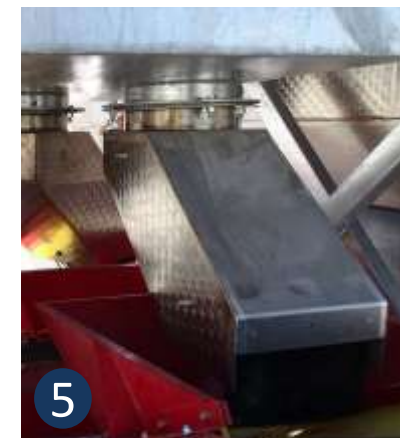



SCREENTEC



MODELS

WASHING | PRESENTATION

MODEL	Deck width		Deck length		Screening area		Deck Number	Capacity tph	Weight			Power					
	mm	feet	mm	ft	m2	ft2			Kg			KW					
VS-150-400	1500	4.92	4000	13.12	6.0	64.58	2 3 4	30-100	2500	3000	3500	5500	6600	7700	7.5	11	11
VS-150-500	1500	4.92	5000	16.40	7.5	80.73	2 3 4	50-200	5000	6000	6500	11000	13200	14300	15	15	18,5
VS-180-500	1800	5.91	5000	16.40	9.0	96.88	2 3 4	50-250	6000	7000	7500	13200	15400	16500	18,5	18,5	22
VS-180-600	1800	5.91	6000	19.68	10.8	116.25	2 3 4	50-280	6500	7500	8000	14300	16500	17600	18,5	18,5	22
VS-210-600	2100	6.89	6000	19.68	12.6	135.63	2 3 4	90-300	7000	8000	9000	15400	17600	19800	18,5	22	30
VS-210-700	2100	6.89	7000	22.97	14.7	158.23	2 3 4	90-300	7500	8500	10000	16500	18700	22000	22	30	37
VS-240-700	2400	7.87	7000	22.97	16.8	180.84	2 3	110-350	9000		9500	19800	20900		37	45	
VS-240-800	2400	7.87	8000	26.25	19.2	206.67	2 3	130-400	15000	18000		33000	39600		45	55	

* The data provided is indicative, the dimensions must be confirmed based on the granulometric curve of the material to be treated.

Sandtec is a hydrocyclone based washing unit designed to recover fines and ultra-fines. It can receive feed in a slurry form (usually from a washing screen) or as dry feed from a conveyor to an optional slurry feed box added to the machine.

- **Sandtec** guarantees the recovery of ~95% of fines over 75 microns and highly accurate elimination of excess fines.
- **Washed product** is discharged with a residual moisture avg <15%.
- **Highly compact and self-contained unit**, easily integrated with existing systems to upgrade capacity and efficiency.
- **Highly customizable** with an extensive options list and project specific builds



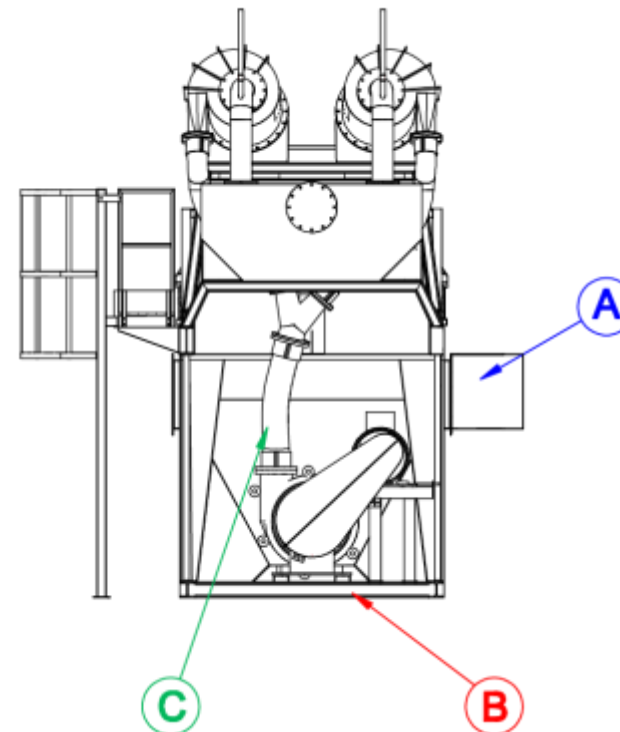
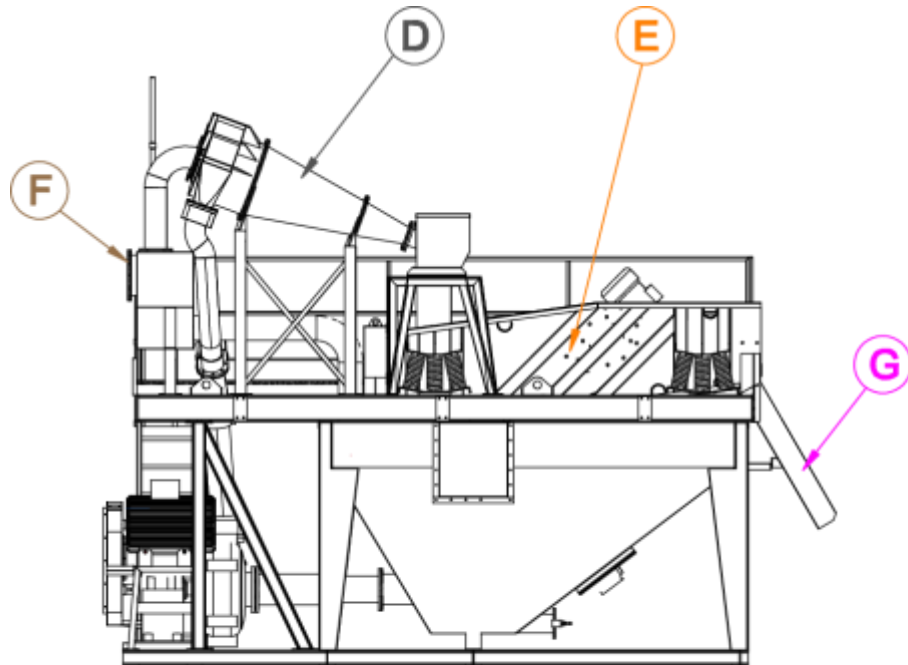

- The slurry composed of a mixture of water, sand, silt, clay, etc. is conveyed to the storage tank through the feeding chute (A).

- The pumping unit (B) positioned in the lower part of the tank sucks up the slurry and sends it to the hydrocyclone through a pipe in antiwear rubber with metal inserts (C).

- The hydrocyclone (D), thanks to a centrifugal movement, causes the liquid-solid separation.

- The underflow, composed of a mixture of sand over 75 microns, containing about 30% of the treated water is sent to the Dewatering Screen (E).

- The overflow, containing particles under 0,1 mm only, is sent to the Water Discharge Chute (F), where the water discharge pipe will be fitted, but which also acts as compensator in case the level of the input water is below that of the treated water.

- The Dewatering Screen fitted with a polyurethane Draining Deck drains the sand and sends it to the Sand Discharge Chute (G).

- The residual water comes out of the draining deck and returns to the Storage Tank.

VERTICAL

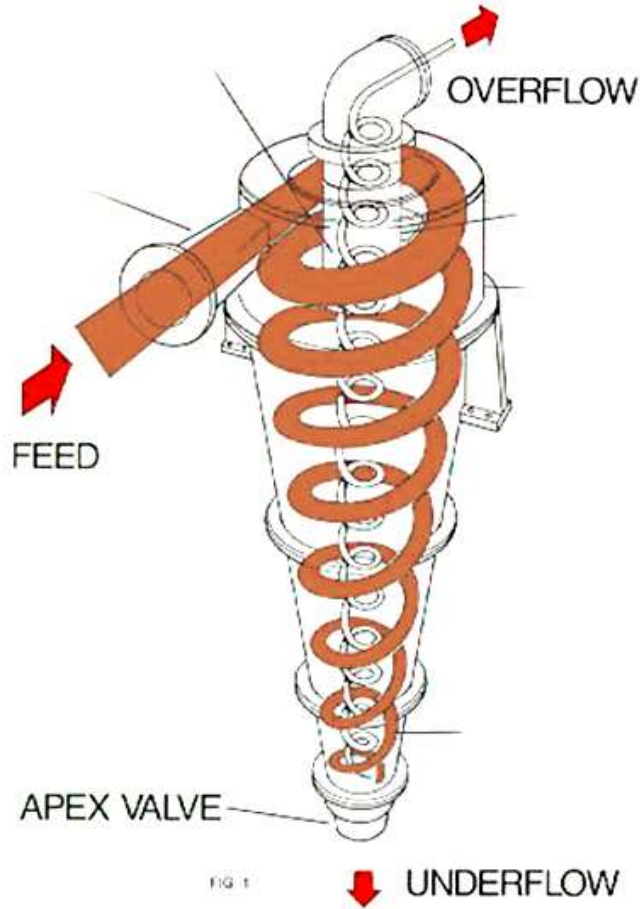

HORIZONTAL

MORE RECOVER CAPACITY

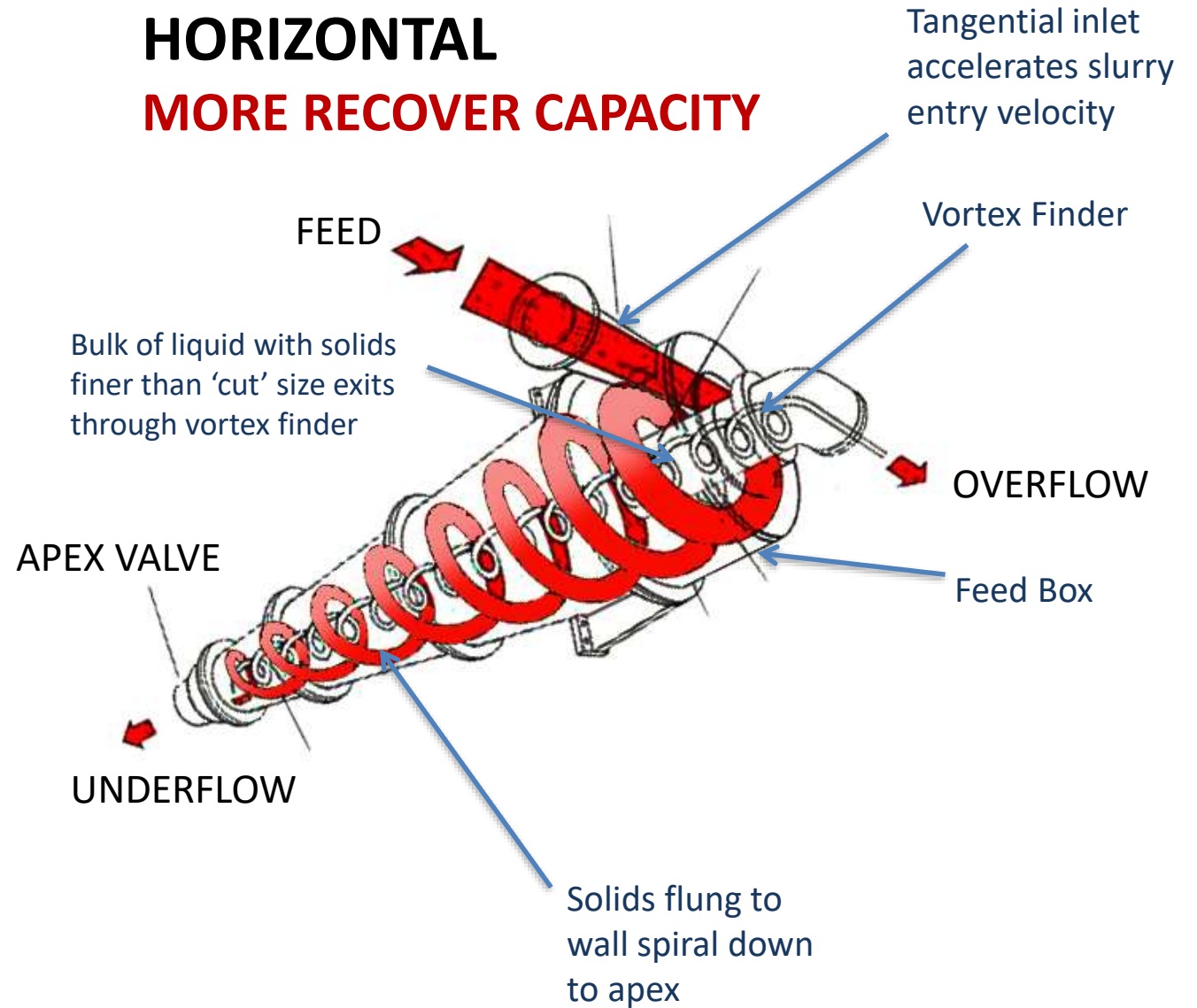

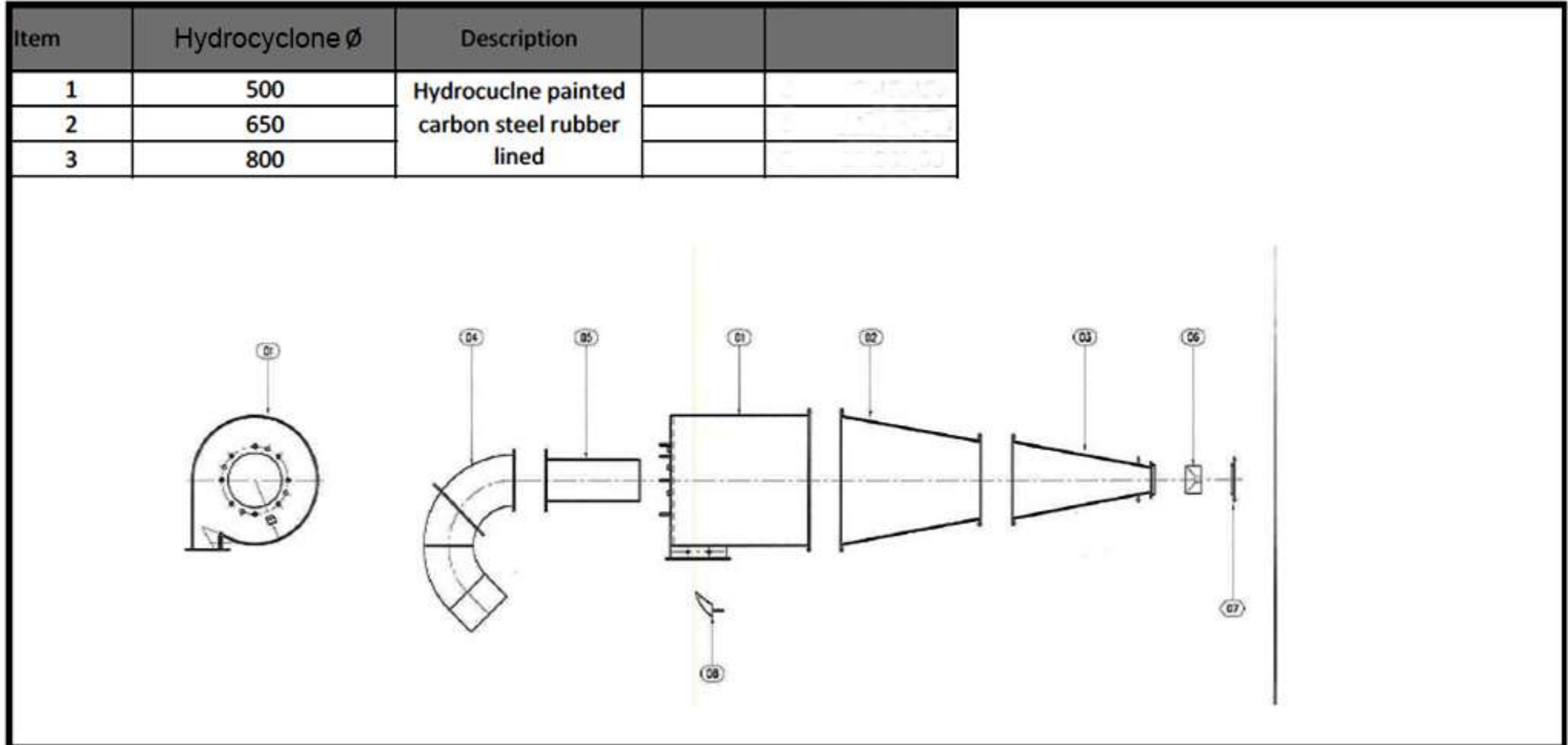



ADVANTAGES

- ✓ MAX RECOVERY OF MATERIAL THROUGH SILT REMOVAL
- ✓ EASY TO ASSEMBLE AND COMPACT
- ✓ EASY MAINTENANCE
- ✓ VERY LOW RESIDUAL WATER CONTENT
- ✓ IT FITS OTHER WASHING EQUIPMENT PERFECTLY

COMPOSED OF:

1. STEEL TANK FOR WATER-SAND-SILT COLLECTION
2. HORIZONTAL SHAFT CENTRIFUGAL PUMP
3. HYDROCYCLONE
4. DEWATERING SCREEN



SUMP TANK

also acting as support for the draining screen, the hydrocyclone and the slurry pumping unit



SLURRY PUMP UNIT composed of heavy or very heavy-duty Warman pump, with metal or elastomer armours, horizontal axle, open or closed impeller according to use, electric motor, belt transmission, suction and input pipe covered with anti-abrasion rubber with metal inserts.



HYDROCYCLONE

composed of a cylindrical body in its initial part, conical in its central and final parts, with internal coating in anti-abrasion rubber.



DEWATERING SCREEN with electromechanic activation by counter-rotative excentric weights, adjustable to increase or decrease the vibrations, draining deck with pull-out polyurethane sections, insulation by means of helicoidal springs.



OPTIONS:

1. Electric Panel on board
2. Hydrocyclone pressure gauge
3. Pit Hydrocyclone
4. Tower Hydrocyclone
5. Additional tamper-proof grids





SANDTEC



MODELS

WASHING | PRESENTATION

MODEL	Waste water flow		Max sand output tph	Cyclones			Dewatering screen			Pump model	Pump Power KW	DS Power KW	Weight		
	Lpm	Gpm		n°	Ø mm	Ø in	width mm	Width ft	length mm				Width ft	Kg	Lb
SH-035-180	3000	792	35	1	500	19,69	900	2,95	1750	5,74	W 6/4	22	1.6+1.6	5000	11000
SH-045-180	3000	792	45	1	500	19,69	1200	3,94	1750	5,74	W 6/4	30	2.2+2.2	5700	12540
SH-065-250	4000	1056	65	1	650	25,59	1200	3,94	2750	9,02	W 6/4	30	2.2+2.2	7300	16060
SH-045-300	5000	1320	45	1	650	25,59	1200	3,94	1750	5,74	W 6/4	37	2.2+2.2	6000	13200
SH-065-300	5000	1320	65	1	650	25,59	1200	3,94	2750	9,02	W 6/4	37	2.2+2.2	7500	16500
SH-080-300	5000	1320	80	1	650	25,59	1500	4,92	2750	9,02	W 6/4	37	3.6+3.6	8000	17600
SH-100-300	5000	1320	100	1	650	25,59	1500	4,92	2750	9,02	W 8/6	37	3.6+3.6	8800	19360
SH-120-350	6000	1584	120	2	500	19,69	1500	4,92	2750	9,02	W 8/6	45	3.6+3.6	9800	21560
SH-120-500	8000	2112	120	2	500	19,69	1500	4,92	2750	9,02	W 8/6	55	3.6+3.6	9900	21780
SH-150-500	8000	2112	150	2	650	25,59	1800	5,91	3000	9,84	W 8/6	55	6+6	12600	27720
SH-150-600	10000	2640	150	2	650	25,59	1800	5,91	3000	9,84	W 8/6	75	6+6	12800	28160
SH-200-600	10000	2640	200	2	650	25,59	1800	5,91	4000	13,12	W 10/8	75	7+7	13700	30140
SH-160-750	12500	3300	160	2	800	31,50	1800	5,91	3000	9,84	W 10/8	90	6+6	14300	31460
SH-160-850	14000	3696	160	2	800	31,50	1800	5,91	3000	9,84	W 10/8	110	6+6	14500	31900
SH-200-750	12500	3300	200	2	800	31,50	1800	5,91	4000	13,12	W 10/8	90	7+7	16000	35200
SH-200-850	14000	3696	200	2	800	31,50	1800	5,91	4000	13,12	W 10/8	110	7+7	16300	35860

* The data provided is indicative, the dimensions must be confirmed based on the granulometric curve of the material to be treated.

The combination of **heavy scrubbing** action and flotation **removal of lightweight contaminants** makes Scrubtec a key component in **Construction & Demolition Waste recycling systems**. It is also ideal for aggregates and mined materials with **high clay content**.



The material is washed through **inclined blades** arranged in series inside the machine. These blades slow down the advance of the material when it is very dirty, but facilitate progress when it is cleaner. The whole washer is lined with interchangeable anti-wear steel armour. The machine is driven by a motor reduction unit.

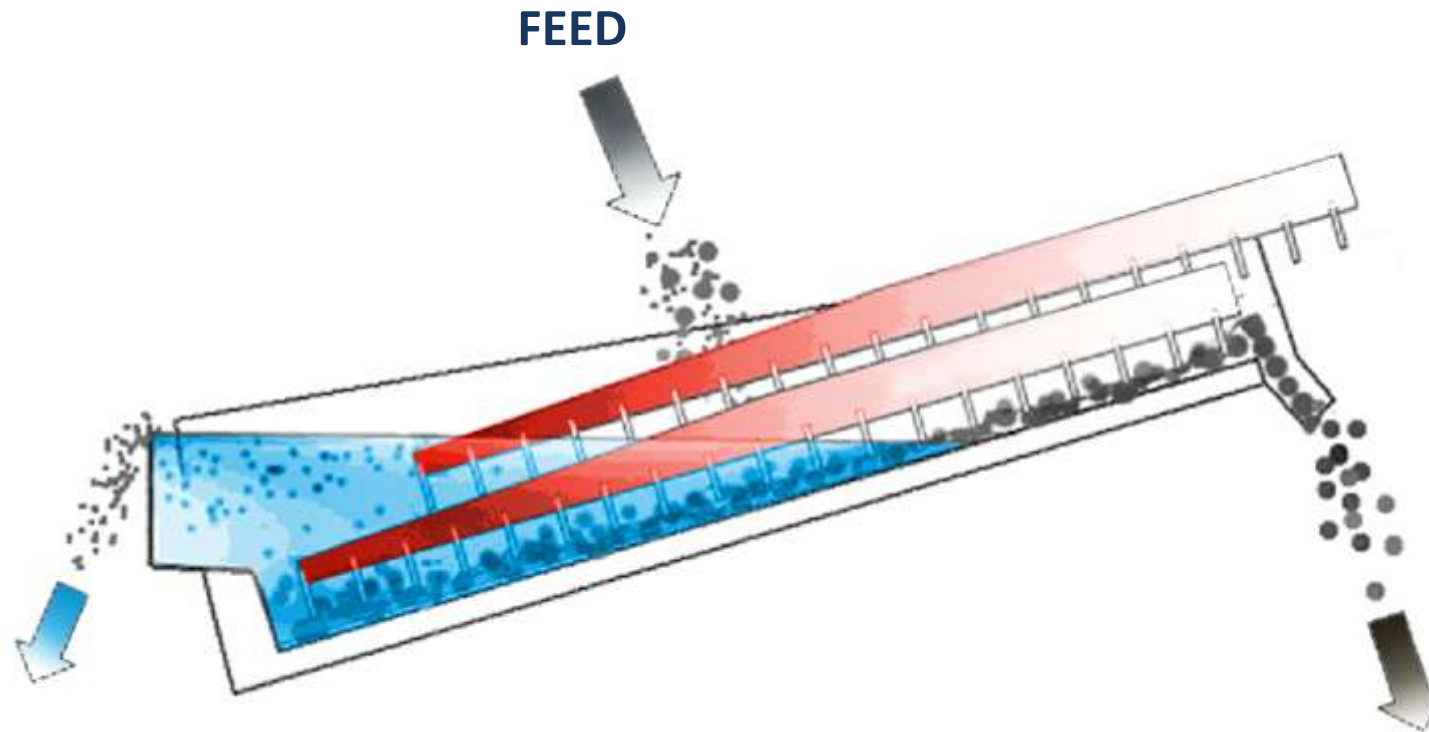

OVERFLOW

Lightweight contaminants / fine sand, most of the water, usually passed to a dewatering screen or SandTec to recover commercially useful fine material

UNDERFLOW

The scrubbed main product. This is usually passed to a dewatering screen or a sizing screen to attain final gradation requirements before stockpiling



ADVANTAGES

- ✓ MODULAR DESIGN FOR EASY INSTALLATION
- ✓ 100% AUTOMATIC
- ✓ EASY TO TRANSPORT
- ✓ BEST EFFICIENCY SCRUBBING

COMPOSED OF:

- ✓ PRE-SCREEN
- ✓ LOG WASHER
- ✓ TRASH SCREEN
- ✓ FINISHING/DEWATERING SCREEN
- ✓ SUPPORTING STRUCTURE ON SKID
- ✓ WATER AND SAND PUMP GROUP

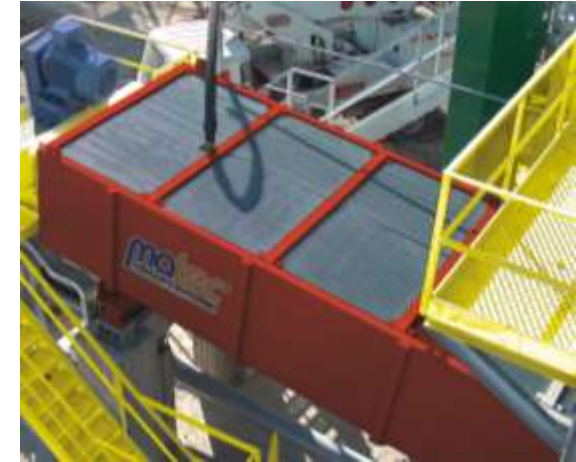

LOG WASHER COMPOSED OF:

- ✓ STEEL TANK FOR WATER-SILT –SAND- GRAVEL COLLECTION
- ✓ ANTI-WEAR STEEL REMOVABLE PADDLE SHAFTS
- ✓ WASHING SYSTEM
- ✓ GEAR BOXES AND ELECTRICAL MOTORS





SCRUBTEC



MODELS

WASHING | PRESENTATION

LW MODEL	Blades diameter		Shaft length		Max feeding size		Capacity	Weight		Power
	mm	ft	mm	ft	mm	inch	tph	Kg	Lb	KW
LW-080-500	800	2,62	5000	16,40	70	2,75	75	10500	23148	2x18.5
LW-095-600	950	3,11	6000	19,69	100	3,93	150	13500	29762	2x30
LW-095-700	950	3,11	7000	22,96	100	3.93	150	14500	31967	2x37
LW-120-600	1200	3,94	6000	19,69	100	3,93	220	16000	35273	2x45
LW-120-700	1200	3,94	7000	22,96	100	3.93	220	17500	38580	2x45

* The data provided is indicative, the dimensions must be confirmed based on the granulometric curve of the material to be treated.

Attritec attrition cells are used to remove contaminants bound to surface of sand. They are most commonly used within circuits producing high-value and high specification sands for industries including glass manufacture / foundries / frac oil production. For example within the glass sand sector Attritec is often used to remove iron contamination on the surface of silica sand particles.

Friction is generated by agitators inside the machine. The machine has **two or more cells** according to the retention time needed to achieve the optimal separation.



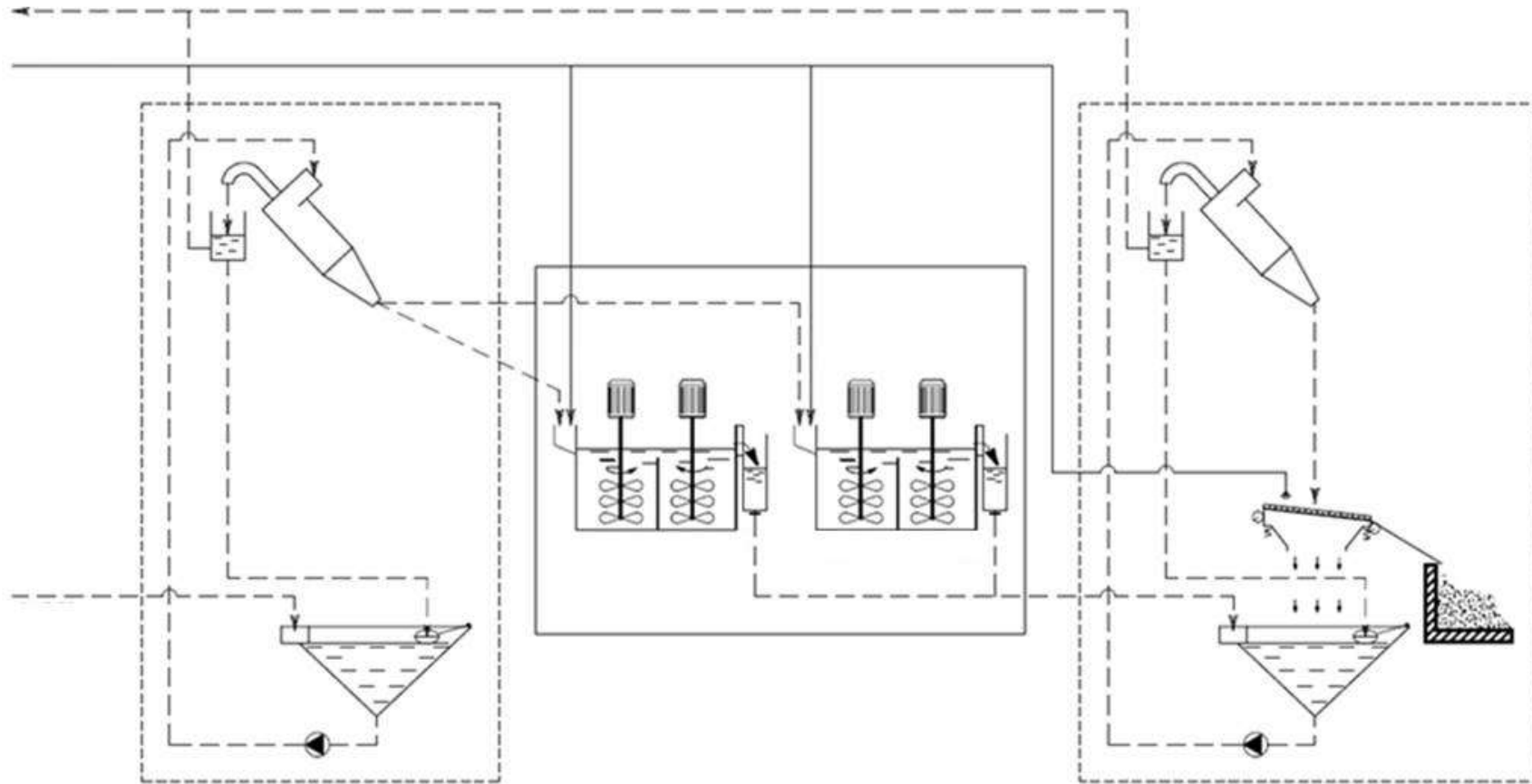

Pre-process with Hydrocyclone

Post-process with Hydrocyclone

As part of the soil-washing process, the **Attritec** provide an effective removal of pollutants on the surface of the sand contained in the contaminated slurry by the action of scrubbing (friction) between particles generated by agitators present in the inside of the machine with consequent production of fine containing impurities. The **intense collisions** between particles of solid material produced by the constant movement in opposite flows of the propellers or by a real turbulence of the slurry, **favor the detachment of all pollutants** from the surface of the sands without, however, reduce the volume of fine particles.

For best results, the ideal concentration of solids in the mixture must be around 60-80%. Depending on the contact times necessary for the achievement of an optimal separation degree of the pollutants, **the machine is supplied with two or more cells** (boxes) since, for the same total volume, a greater number of compartments ensures greater efficiency. The individual cells are made of steel and are coated internally with wear-resistant panels of different typology easily replaceable. The agitators can be provided with replaceable wear-resistant blades or with blades coated with vulcanized natural rubber in the presence of particularly abrasive materials.



The attrition cells usually find their ideal location before the hydrocyclonic process of the slurry and their applications are as follows:

- for contaminated sites (soil-washing): the soil particles are washed in order to disgregate the contaminants from their surface
- for the pre-flotation treatment of the slurry: the washing of the particles before the flotation process guarantees an increase in the selectivity and a reduction of consumption of reagents
- for the mechanical preparation of minerals
- for the separation of grains of sand from minerals and cement purposes
- for the removal of clay and iron stains from silica sand intended for the glass industry
- for the break-up of balls of clay and bituminous material
- for the recovery of valuable minerals which may be present on the sand grains
- for intensive conditioning
- for the salt industry (refining)
- for lime slaking





ADVANTAGES

- ✓ INTENSIVE TREATMENT FOR SLURRY O SAND
- ✓ POLLUTANTS REMOVAL
- ✓ ROBUST DESIGN
- ✓ WEAR-RESISTANT

COMPOSED OF:

- ✓ STEEL PLATE BOX
- ✓ DRIVE SHAFTS MADE OF HIGH RESISTANCE STAINLESS STEEL
- ✓ DOUBLE EASY REMOVABLE IMPELLERS MADE OF WEAR RESISTANT STEEL
- ✓ SEPARATION DIAPHRAGM BETWEEN THE CHAMBERS
- ✓ REPLACEABLE, WEAR-RESISTANT COATING MADE OF RUBBER SHEET



MODEL	Volume	Power
	m ³	Kw/h
AT-200 (2 cells)	100	5.5x2
	220	7.5x2
	270	9.2x2
	650	15x2
	1300	22x2
AT-300 (3 cells)	100	5.5x3
	220	7.5x3
	270	9.2x3
	650	15x3

* The data provided is indicative, the dimensions must be confirmed based on the granulometric curve of the material to be treated.

Buctec bucket wheel dewaterers are relatively conventional washing units, are used for the recovery of sand / fine materials. Most frequently used in the quarry and sand industries they are also applied to a wide range of washing projects for various minerals and mined materials. coming from aggregate washing plants.

Whilst they do not offer the same efficiency and separation accuracy of Sandtec systems they do remain an attractive option for many operators:

- Easy to install
- Relatively low cost
- Simple engineering: basic maintenance requirements
- Well known by operators across the world



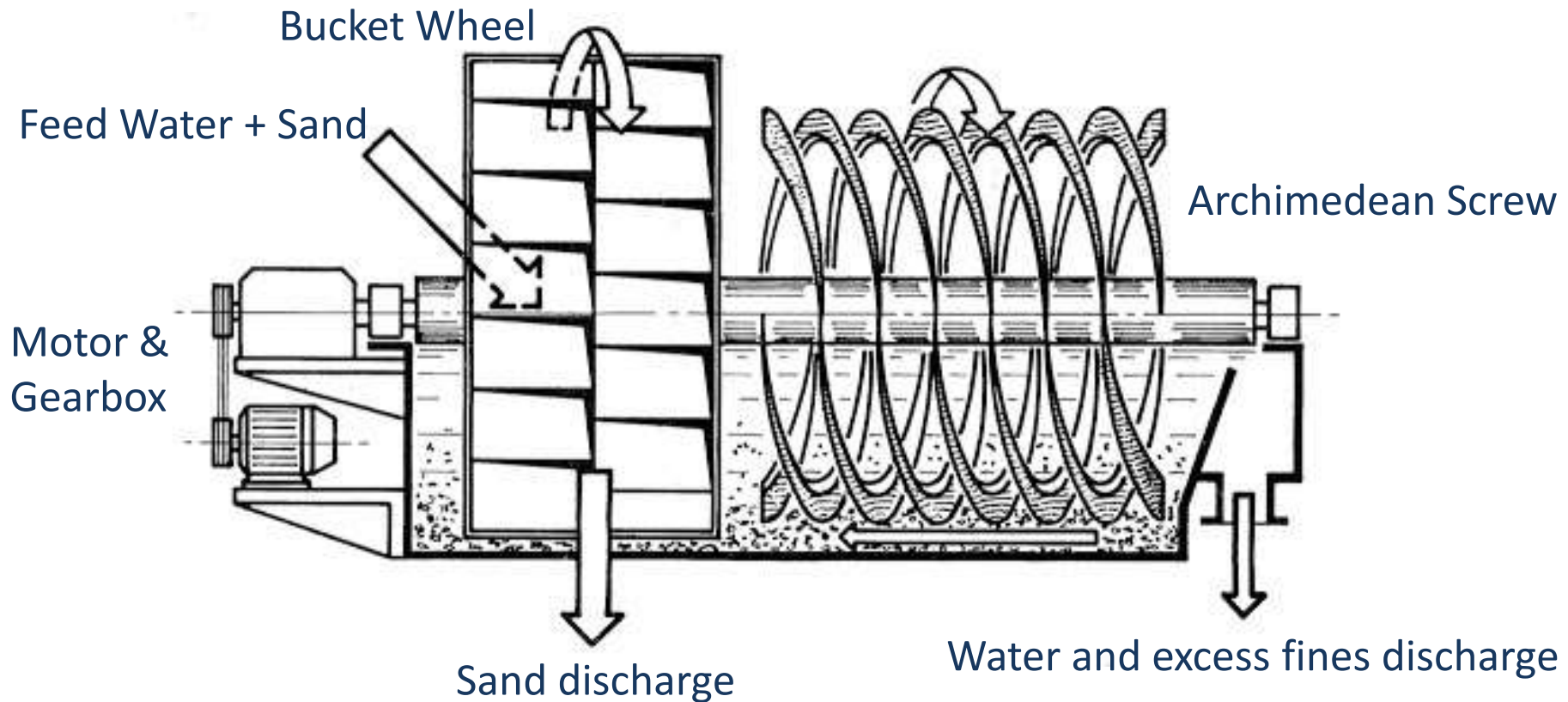

These machines are composed of a main sand slurry reception tank, an Archimedean screw and one or two bucket wheels. Fines slurry enters the main tank and is then drawn towards the buckets by the screw. Sand is lifted from the slurry by the buckets which have perforations to allow water to drain back to the tank. Excess fines / low density contaminants overflow the main tank by means of a weir system.



ADVANTAGES

- ✓ UP TO 2 GRADES OF SAND
- ✓ SIMPLICITY
- ✓ MAXIMUM VERSATILITY
- ✓ COMPLEMENTARITY
- ✓ LOW RUNNING COSTS
- ✓ LOW MAINTENANCE

COMPOSED OF:

1. TANK FOR WATER-SAND-SILT COLLECTION
2. 1, 2 OR 3 BUCKET WHEELS
3. ARCHIMEDEAN SCREW
4. GEAR BOX AND ELECTRICAL MOTOR

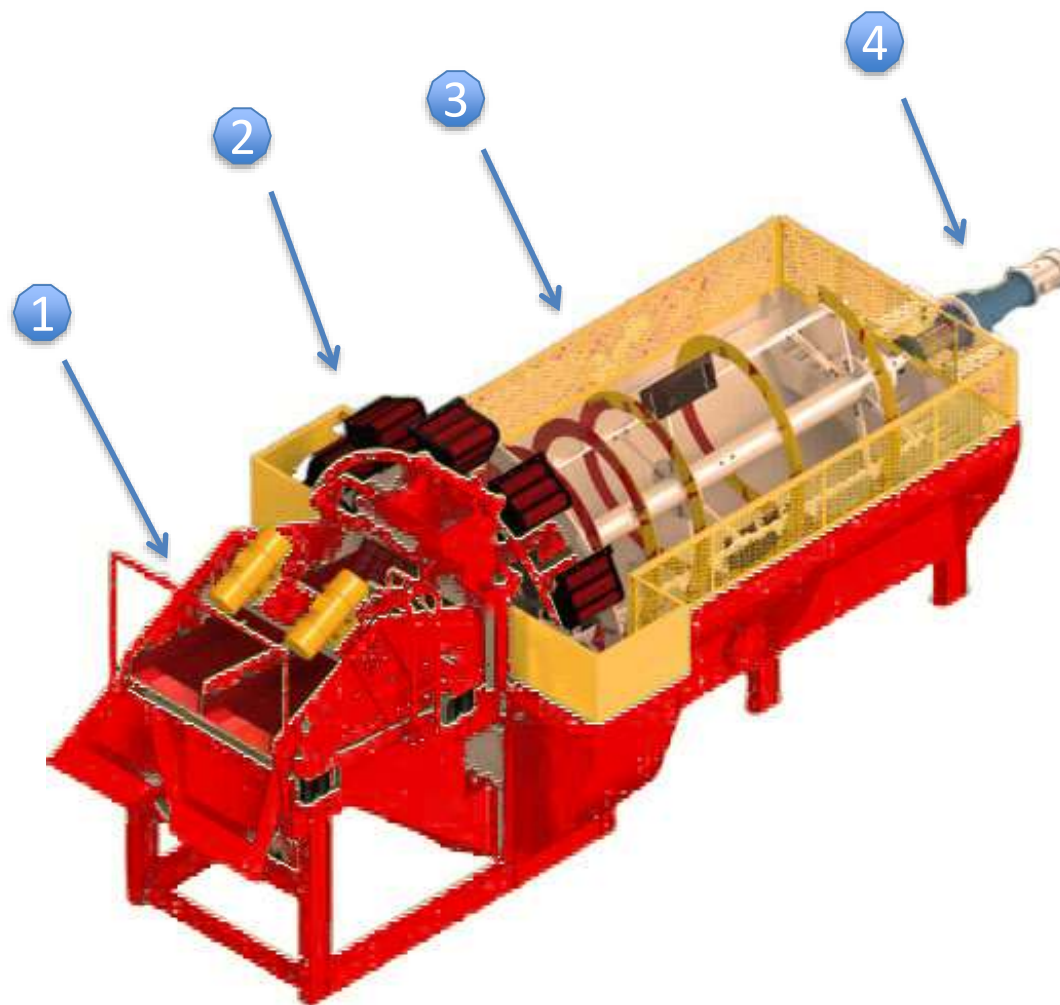

BR MODEL	Wheel diameter		Bucket Width		Max Capacity		Weight		Power
	mm	ft	mm	in	M ³ h	tph	Kg	Lbs	KW
BT-200-030	2000	6,56	500	19,69	20	30	1700	3740	2
BT-200-050	2000	6,56	750	29,53	30	50	2000	4400	3
BT-240-080	2400	7,87	1000	39,37	50	80	2700	5940	4
BT-240-110	2400	7,87	1300	51,18	70	110	3000	6600	5,5
BT-300-160	3000	9,84	2x800	2x31,50	100	160	4500	9900	11
BT-400-220	4000	13,12	2x800	2x31,50	140	220	6500	14300	7,5x2
BT-500-400	5000	16,40	2x1500	2x59,6	250	400	12000	26400	11x2

* The data provided is indicative, the dimensions must be confirmed based on the granulometric curve of the material to be treated.



WASHING | REFERENCE



THE EXCELLENCE IN FILTRATION, BY NATURE



Customer: **H&H**

Location: **Poland**



SCRUBTEC: two log washers.

SCREENTEC: two vibrating screens.

SANDTEC: SH 150-500



Customer: **Clamens**

Location: **France**



Sandtec SH-007-040S



Customer: **Orlatti**

Location: **France**



Equipment: **Sandtec SH-1000-HP**



Customer: **Transkom**

Location: **Poland**



Equipment: **Sandtec SH 080 300 - SH 150 500**



Customer: **Finlay**

Location: **Australia**



Equipment: **Sandtec SH 120 500**



Customer: **Gerber**

Location: **Switzerland**



Equipment: **Sandtec SH-025-120S**



Customer: **Micoperi**

Location: **Italy**



Sandtec SH 025-180
Screenotec VS 150-402



Customer: **Carrara Marble Way**

Location: **Italy**



Equipment: **Aggretec 150**

SEMI-MOBILE PROJECTS

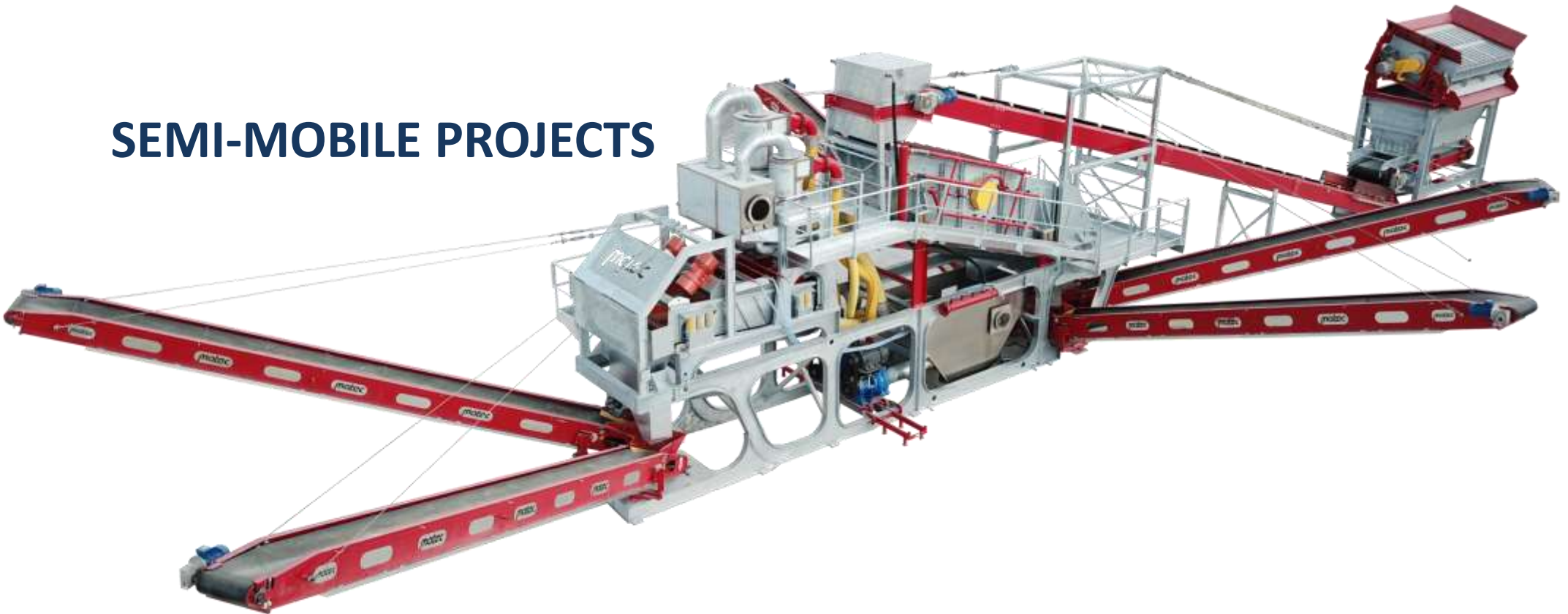





Gumustas – Turkey
n°2 Sandtec SH-150-500
Start up in **March 2020**



Carriere Spie Batignolles – France
Aggretec 150
Start up in **April 2020**
Carriere CCU – France
Screentec VS-150-502
Start up in **May 2020**



Fortume Waste Recycling Solutions AB – Sweden
Aggretec 50 + Scrubtec
Start up in **July 2020**



Koegler – Austria
Aggretec 150
Start up in **June 2020**



Crown Aggregates – UK
Aggretec 150
Start up in **August 2020**



matec
machinery technology

20
years experience

100
employees worldwide

120
dealers around the world

6
factories worldwide

VIÇENZA - HEADQUARTERS

Via Aurelia Ovest, 383 - 54100 Massa (MS) Italy - tel. +39.0585.831034 - Fax +39.0585.835598
matec@matecitalia.com - www.matecitalia.com